STUDYING THE FEATURES OF OPTICAL LASER-BASED RANGING SYSTEMS

G.F. ATTIA¹, I.A. HASSAN² and R. GHONEIM¹

National Research Institute of Astronomy and Geophysics, Helwan, Egypt.

²*Dept. of Astronomy, AL-Azhar University, Egypt.*

Abstract

The increased requirements on ranging precision in many military, industrial and astronomical applications illustrate the importance of the Laser ranging systems (called Laser radar) as a modern ranging system. In this paper, the authors study the main features of laser ranging systems in its two main modes, the pulsed mode and the continuous wave subcarrier mode (CWSM). The main advantages of each mode are discussed then proved out by experimental data given by the satellite ranging system Helwan and an experimental setup built on the bases of CWSM. These results show good agreement with that expected theoretically.

Keywords:

Laser ranging, Laser rader, Laser range finder, Lidar, Ladar, Laser metrology, Laser systems, Optical ranging.

1. Introduction:

Lidar [1-4], light detection and ranging, or ladar, laser detection and ranging systems were first introduced in the late 1960s and early 1970s. Their initial use was applied to many applications such as surveying, tactical laser range finders and beam rider missile guidance systems. The main advantages of ladars are its small size and very high angular accuracy values.

In this work the principles of laser ranging measurements is described in its two main modes the pulsed mode and the continuous wave subcarrier mode (CWSM). The main advantages of each mode are discussed. Two systems are employed to illustrate the main advantages of each system; the first is the pulsed laser ranging system (Helwan) used to collect a new set of data for the satellite "Lageos-1". The second is a high accuracy CWSM based system designed and implemented as a small range laser ranging system with very small blind range.

2. The Ladar Range Equation:

Optical radar methods for distance measurement are essentially based upon the determination of the transit time of flight between a fiducial point and the target of interest. There are basically two approaches to this measurement [5,6]:

1. **Direct-Pulsed mode:** where the round trip time (time of flight τ_d) of a short pulse of light is directly timed. The range R is given directly by the equation

$$R = c \tau_d / 2 \quad (1)$$

where c is the free space speed of light. This technique is mainly used for measurement of medium and long distances, as example for satellite ranging systems. Due to the very fast electronics required for this approach, few attempts have been made to exploit this technique for short-range distance measurement.

2. **Indirect-Continuous wave subcarrier modulation (CWSM) mode:** where the intensity of the source is modulated at high frequency and the distance is determined from the change in phase induced in the subcarrier during the transit of the light.

2.1 Pulsed mode laser ranging:

In this technique, the laser transmitter transmits a very short, high power optical pulse using Q-switching [7], or any other technique of producing very short optical pulses. By measuring the time delay of the reflected pulse, the range can be determined directly from equation (1).

The maximum unambiguous range R_{max} is a function of the inter-pulse period T , as given by ($R_{max} = c T/2$). Beyond this range, the elapsed time between transmitted and received pulses will include multiples of T , making the range ambiguous. Practically, T is very large such that we can say that R_{max} is unlimited. Another factors that may limit the maximum range R_{max} are the optical beam geometry, atmospheric attenuation, target cross-section,, etc [8]. The pulse width τ_p is chosen to be very small since the minimum detectable range (dead range) R_{min} should be smaller or equal to ($c \tau_p/2$) to avoid the overlapping of the transmitted and received pulses. It is well known that the optical energy associated with the pulse is $E_0 = P \tau_p$, where P is the optical power during the pulse. As τ_p decreases, the optical energy decreases, which requires a huge power to give enough energy. The main advantages of this technique, is the unlimited range (from signal processing point of view). But the main drawback of pulsed technique is that there will be a blind range (about 145-200 m) through which no target can be detected. This blind range comes from the very short time of flight of light that overlaps the transmitted and received pulses, hence the time of flight can not be measured.

2.2 Continuous wave subcarrier modulation (CWSM):

CWSM is one of the standard techniques used in both conventional and optical radars. It is utilized in optical radar when the displacement resolution required is much greater than the wavelength of the source. The basis of this method is that the wavelength of the source can be increased by several orders of magnitude to an effective wavelength λ_m by imposing an intensity modulation of the form

$$I = I_0 \sin(\omega_m t), \quad (2)$$

where I_0 is the amplitude and ω_m is the angular frequency. Consider a diode laser driven by sinusoidal input current that produces intensity modulated laser beam. Hence the laser beam intensity will be in the form

$$I_T = I_{0T} \sin(\omega_m t + \phi_L), \quad (3)$$

where I_T is the intensity of the transmitted wave, I_{0T} is the maximum transmitted intensity, and ϕ_L is the phase shift in the laser. After the laser beam has been

collimated, it is splitted by a beam splitter into two beams. The first beam is intercepted by a photo-detector, where it is taken as a reference signal. The second beam travels to the target, where it is reflected back and focused by converging lens on a photodetector. The output signals from the two photodetectors are amplified and reshaped. The reference signal will be in the form

$$I_{R1} = I_{OR1} \sin(\omega_m t + \phi_L + \phi_d + \phi_a), \quad (4)$$

where I_{R1} is the intensity of the reference signal, I_{OR1} is the maximum intensity of the reference signal, and ϕ_d and ϕ_a are the phase increase due to the detection and amplification of the light at the receiver. The target signal will be in the form

$$I_{R2} = I_{OR2} \sin(\omega_m t + \phi_L + \phi_R + \phi_d + \phi_a), \quad (5)$$

where I_{R2} is the signal intensity reflected from the target signal, I_{OR2} is its maximum intensity and ϕ_R is the phase shift introduced due to flight of light a distance $2R$, where R is the range to be determined and is given by

$$\phi_R = k_m \cdot 2R, \quad (6)$$

where $k_m = 2\pi/\lambda_m$ is the angular wave number, and λ_m is the modulation wavelength. The two signals (reference signal and signal from the target) are amplified then reshaped into pulses and compared in a phase detector where the phase difference $\Delta\phi$ between these two signals is measured, where $\Delta\phi$ is given by

$$\Delta\phi = \phi_R. \quad (7)$$

The phase difference $\Delta\phi$ is directly proportional to the range and given by

$$R = c (\Delta\phi) / 4 \pi f_m, \quad (8)$$

where $f_m = c/\lambda_m$ is the modulation frequency. Thus the range R can be measured. The accuracy of the range measurement depends on the accuracy with which the phase difference $\Delta\phi$ can be measured [9,10]. The maximum range R_{max} decreases as the modulating frequency f_m increases. The choice of the modulating frequency doesn't only depend on the maximum range R_{max} , but also on the required accuracy of measurement to be achieved [7]. It is important to define the main features of CWSM system, which are:

- **The Maximum Unambiguous Range (R_{max}):**

The maximum value of phase shift ($\Delta\phi_{max}$) equals (2π) radian. This corresponds to the maximum unambiguous range of the system R_{max} that can be calculated from

$$R_{max} = \frac{c}{4 \pi f_m} (2 \pi) = \frac{c}{2 f_m} = \frac{\lambda_m}{2}, \quad (9)$$

which shows that as f_m decreases (λ_m increases) the value of maximum unambiguous range increases. Theoretically, the value of R_{max} is unlimited, but it is well known that the noise level of the system at low frequencies is very high which limits the minimum value of modulating frequency and hence the maximum value of R_{max} .

- **The Minimum Detectable Range R_{min} :**

The minimum detectable range R_{min} which is governed by the noise level of the system. If the noise level is N , and the signal level is S , the minimum detectable phase shift is given by

$$\pm \Delta\phi_{min} = \pm \sin^{-1}(N/S). \quad (10)$$

Provided that $N \leq S$ which proves that as the signal to noise ratio increases, $\Delta\phi_{min}$ decreases. If equation (8) and (10) are combined, then the minimum detectable range is given by

$$R_{min} = \frac{c \Delta\phi_{min}}{4\pi f_m}. \quad (11)$$

For the same value of $\Delta\phi_{min}$, the minimum detectable range R_{min} decreases as f_m increases.

- **The system Dynamic Range:**

The system dynamic range of R_d is defined as the ratio of the maximum unambiguous range to the minimum detectable range. In our system, the dynamic range is given by

$$R_d = R_{max}/R_{min} = 2\pi/\Delta\phi_{min}, \quad (12)$$

which indicates that for the same value of $\Delta\phi_{min}$, the dynamic range is independent of the modulating frequency f_m and increases as the value of $\Delta\phi_{min}$ decreases, which shows the great importance for the system enhancement to reduce the noise level in the system. Theoretically, $\Delta\phi_{min}$ is the minimum detectable phase shift of the phase detector, but practically, its value depends on the used electronics. In our case, the value of $\Delta\phi_{min}$ is $1m$ radian, but practically its value becomes $4.188 m$ rad. due to electronics, which results in the decrease of the dynamic range from 6283.185 to 1500 .

3. Experimental Systems:

a) Pulsed system:

A block diagram of the satellite laser ranging system Helwan is shown in Figure (1). A CCD camera is used for star tracking which gives a synchronization signal to the whole system when the star is locked. This signal triggers a Q-Switched Nd-YAG laser that produces very narrow ($17 ps$), very powerful ($30 mJ/pulse$) optical pulses of wavelength 0.53 microns. A trans-receiver telescope is used to send these pulses to the target then receives them back. A digital control and computing system is used to statistically determine the range of the satellite. At $19:13$ during the night of $18/7/1999$ more than 230 laser pulses were fired towards the satellite "Lageos-1". The time of flight of each pulse was observed then the range residuals, the difference between the observed time and that calculated for the satellite (the $O - C$ residuals), is determined.

The Principle of Laser Ranging:

Figure (2) shows a simplified block diagram of the principles of satellite laser ranging system. A portion of the outgoing laser pulse is detected by the photodiode, which starts the time of flight measurements. The remainder of the pulse propagates through the atmosphere to the satellite where it is reflected by the retro-reflectors back to the receiving telescope. The telescope collects and focuses the returning laser pulse on a photomultiplier and the resulting signal stops the time of flight measurements. A digital word representing the round trip time of flight is stored by the computer with the epoch time of the measurements and other supporting information.

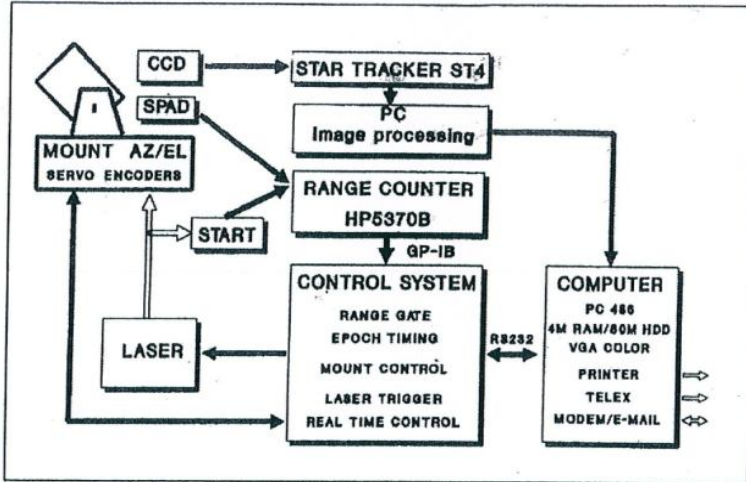

Fig.(1): A Simplified block diagram of the pulsed mode laser ranging station Helwan.

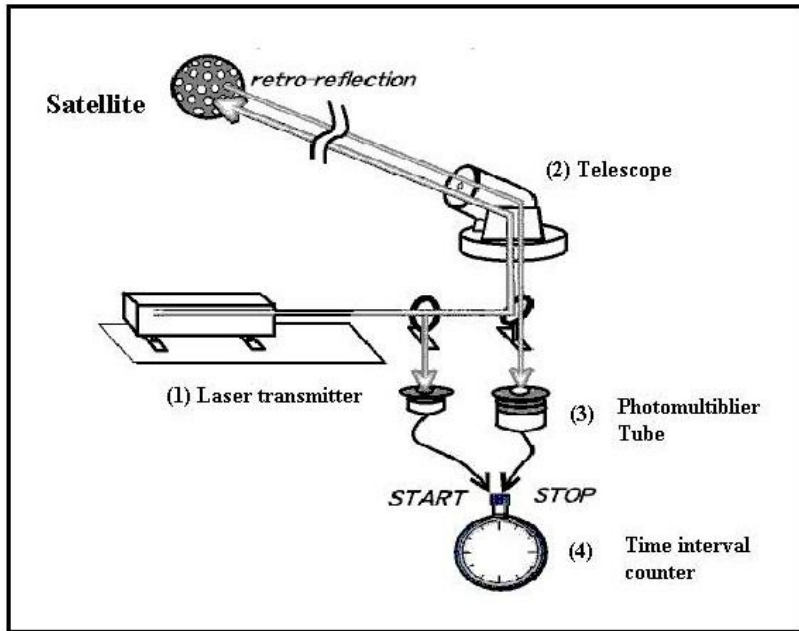

Fig.(2): Block diagram of SLR technique.

Helwan Satellite Laser Ranging Station:

In Satellite laser ranging (SLR), a global network of stations measure the instantaneous round trip time of flight of laser pulses to satellites equipped with special reflectors. This provides instantaneous range measurements with good precision, which can be accumulated to provide accurate orbit measurements and a host of important science products.

The Helwan station uses a Nd:YAG laser transmitter which produce sharp pulses of monochromatic high energy in a beam with a very low angle of divergence. With the same importance, are the nanosecond rise time electronic instrumentations to handle these optical signals. The fast rise time and short width laser pulses make the time interval measurements at nanoseconds resolution possible.

It is important to mention that the monochromatic nature of the laser output allows for efficient filtering to improve the signal to noise ratio. By the continuous upgrading of the laser radar systems, the precision of single shot ranging observations has improved from centimeters level to a few millimeters level.

Description of the Equipments of Helwan-SLR Station:

Helwan satellite laser ranging station consists of two axial mount with its emitter and receiver, Laser transmitter, Laser ranging electronics, meteorological instrumentations, Global positioning system (GPS), and PC computer with advanced software and hard ware.

The Mount with Its Emitter and Receiver:

The mount, which is used in the Helwan satellite laser ranging station, is of an azimuth- altitude system. The shape of the mount is shown in Figure (3). The system of the mount consists of two-step motors, one step motor to direct the azimuth axis and the other one to drive the altitude axis. Each motor has a reduction gear box and a worm gear, allowing for reducing the velocity in the ratios 1:4 and 1:360 respectively. A control unit set is graduated to 0.00125 degrees for azimuth and altitude. Fine adjustments also provide the system of the mount.

There are two telescopes, one of them is the master and the other is the slave. Both are mounted with parallel to the longitudinal axis of the cylinder. The distance between the axis of the master telescope and the vertical mechanical axis of the mount is 0.56 m. We have to emphasize that the horizontal mechanical axis is taken for granted to be perpendicular to the vertical mechanical axis of the mount, which is adjusted by the help of a water bulb balance to be perpendicular to the plane of the horizon.

Because of the azimuth- elevation type of the mount, it follows that, as the elevation of the satellite to be tracked approaches 90°, the rate of change in azimuth approaches infinity. This means that there are small angular regions near the zenith where the system can't track the satellite, as the azimuth axis drive can't move with sufficient velocity. The maximum azimuth driven rate for the mount is 1 degree/sec and the maximum elevation driven rate is 0.5 degree/sec.

For operation, the computed predictions of satellite azimuth and altitude are fed to the step motor control unit on a point-by-point real time bases by PC-computer. The emitter of the telescope is the part of the mount that transmits the laser beam

from the laser transmitter to the satellite or the target. There are four Caudé mirrors, which direct the laser beam from the laser transmitter to the emitter of the mount. These mirrors are dielectric of reflectivity 99%. The photoelectric receiver is the part of the telescope, which receives the signal, which is reflected from the satellite. It consists of an aperture, a spherical lens of diameter 40 cm that collects the light to the photo multiplier, and an interference filter of 6 nanometers wide and of 80% transmission.

The Laser Transmitter:

The laser transmitter which is used at the Helwan satellite laser ranging station consists of a passively mode locked oscillator, pulse selector, and a system of three amplifiers. The photograph of the laser generator and the block diagram of its construction is shown in Figures 4 and 5. This laser transmitter produces a semi-train of laser pulses with output pulse energy of 80 mJ and pulse width of 17 picosecond at a wavelength of $0.53\ \mu\text{m}$. The detailed descriptions of the laser transmitter are given in [11 & 12].



Fig.(3): The mount of Helwan-SLR station.



Fig.(4): The Nd:YAG laser transmitter of the Helwan satellite laser ranging station.

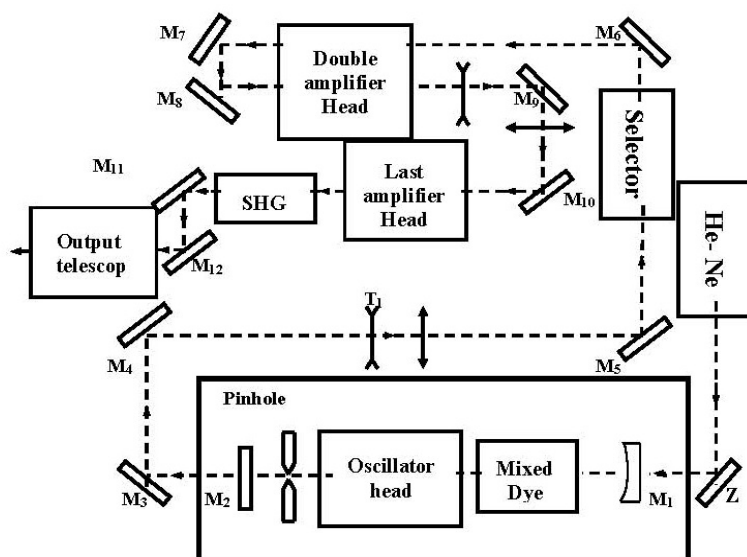

Fig.(5): Block diagram of the mode locked Nd:YAG laser transmitter.

The Laser Ranging Electronics:

The laser ranging electronics that are used in Helwan SLR station consists of a photomultiplier tube of type Hamamatsu *H6533* box with PMT Tube *R4998*. This PMT has a large photocathode, which yields to a very simple and easy optical adjustment. On the other hand, a high voltage power supply of type Tennelec TC 952A is used as a source for the PMT in order to supply with stable voltage of 2500V. Moreover, EG&G Ortic *1 GHZ* pre-amplifier model 9306 and Quad Tenellec discriminator TC454 are also involved.

The time interval counter is also considered to be one of the most important parts of the laser electronics. It is known that any SLR station has to measure the time of flight of a laser pulse from the station to the satellite and returned back. To get the highest possible accuracy for the distance, this time interval has to be measured as accurate as possible. This is done in Helwan-SLR station using the *SR620* time interval counter, which has a high single shot timing resolution, low jitter and outstanding flexibility. This counter measures the time intervals with a RMS resolution reached 25 picoseconds (ps).

The *SR620* is a full-featured time and frequency counter, capable of measuring frequency with 11 digits of resolution or, time intervals as small as 25 Ps. It also measures pulse width, rise/fall time, period, phase, and event counts. Statistics are automatically calculated and reported on samples as large as one million, including: sample mean, maximum, minimum, and standard deviation or Allan variance. Standard GPIB and RS-232 interfaces control all front panel functions, and printers or plotters can be directly connected to the count. Table (1) shows an example of part of the data of the observation of the satellite Topex. The first raw of Table (1) represents the date of observations 00/6/10 in year 2000, month 9 and day 4 respectively as well as the satellite identifying number (eg. 92052010 for the satellite Topex). The second raw represents the corresponding temperature, humidity percentage and pressure at the time of observation (28.8.0°C, 37% and 999 mb respectively). Starting from the third raw, there are ten columns. The number of laser shots is shown in the first column. The time of observations in hour, minute and second is represented in the second, third and forth columns respectively. In the fifth column, the observed range of the satellite in milliseconds (ms), ($1\text{ ms} \cong 150\text{ km}$) is shown. The on-line residuals of the observed minus the computed ranges (O-C) in microsecond (μs), the off-line residuals (O-C) in nanosecond (ns) and the polynomial fitting of the residuals in nanosecond are given in the columns six, seven and eight respectively and these will be discussed in details in the next section as well as the analysis procedures of the satellite laser ranging data. The value related to the mount correction which is known by the dummy is shown in column 9. The last column represents the weight of each point from the polynomial fitting either 0 or 1 (0 for the points which don't agree with the fitting) (Figure 6).

Table (1): Part of the SLR data obtained for the satellite Topex.

00 06 10		92052010				0. 0 0 1			
no.Las.	h	m	s	O-C		range (ms)			
on line		off line		poly. fit					
8	19	16	8.0002810	15.84076620	-0.111	-0.43	-1.40	0	0
10	19	16	8.4002839	15.83152337	-0.110	0.95	0.02	0	1
11	19	16	8.6002841	15.82690615	-0.104	1.50	0.59	1	0
33	19	16	13.0002797	15.72604572	-0.107	-0.11	-0.67	0	0
40	19	16	14.4002819	15.69425012	-0.102	-0.58	-1.03	1	0
67	19	16	19.8002823	15.57297712	-0.086	0.81	0.70	3	0
69	19	16	20.2002827	15.56408021	-0.092	0.08	-0.01	2	1
74	19	16	21.2002800	15.54189452	-0.084	1.63	1.60	3	0
107	19	16	27.8002792	15.39738260	-0.087	-0.57	-0.29	2	0
156	19	16	37.6002808	15.18914556	-0.083	1.22	1.82	1	0
157	19	16	37.8002846	15.18497499	-0.089	-0.31	0.30	0	0
163	19	16	39.0002814	15.16002989	-0.078	-0.68	-0.05	2	1
164	19	16	39.2002810	15.15588488	-0.083	0.24	0.88	1	0
169	19	16	40.2002792	15.13520574	-0.086	1.19	1.85	0	0
173	19	16	41.0002800	15.11871923	-0.088	-0.87	-0.19	0	0
193	19	16	45.0002812	15.03709913	-0.084	-0.83	-0.08	0	1
201	19	16	46.6002823	15.00482937	-0.078	-0.28	0.49	1	0
310	19	17	8.4002824	14.58749986	-0.061	-0.62	0.24	1	0
311	19	17	8.6002818	14.58387012	-0.061	-0.79	0.07	1	1
313	19	17	9.0002802	14.57662235	-0.066	-0.62	0.23	0	0
315	19	17	9.4002821	14.56939105	-0.049	1.15	2.00	3	0
322	19	17	10.8002805	14.54419159	-0.060	-0.70	0.15	1	1
324	19	17	11.2002797	14.53702667	-0.048	-0.12	0.73	3	0
327	19	17	11.8002802	14.52630615	-0.064	-0.61	0.23	0	0
328	19	17	12.0002813	14.52274012	-0.064	-0.83	0.01	0	1

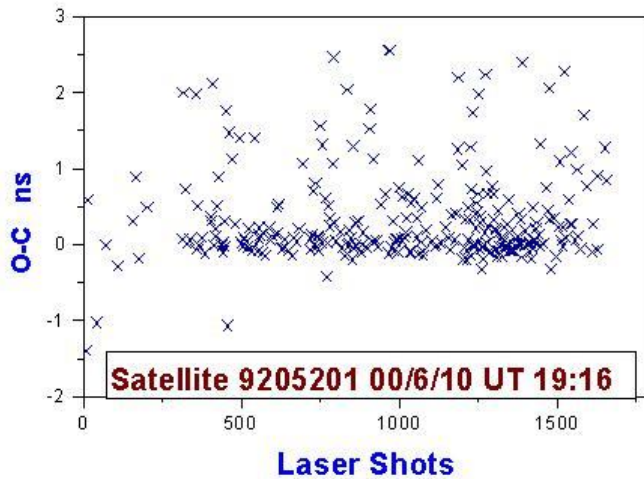

Fig.(6): Range residual in ns v.s No. of laser shots as plotted for the satellite Topex.

b) Realization of a CWSM laser ranging system:

The system was designed to cover a range of 150 m , with accuracy of $\pm 10\text{ cm}$, and dynamic range of 1500. A schematic diagram of the system is shown in Figure (7). It consists of an optical transmitter and optical receiver. The transmitter, which produces a collimated, intensity modulated laser beam, consists of a stable oscillator to modulate the diode laser in range of frequencies 0.5 MHz to 3.5 MHz . A diode laser module RS 194-004 was used to produce a beam of wavelength 670 nm and output power of 3 mW . An optical system is used to focus the beam onto the target.

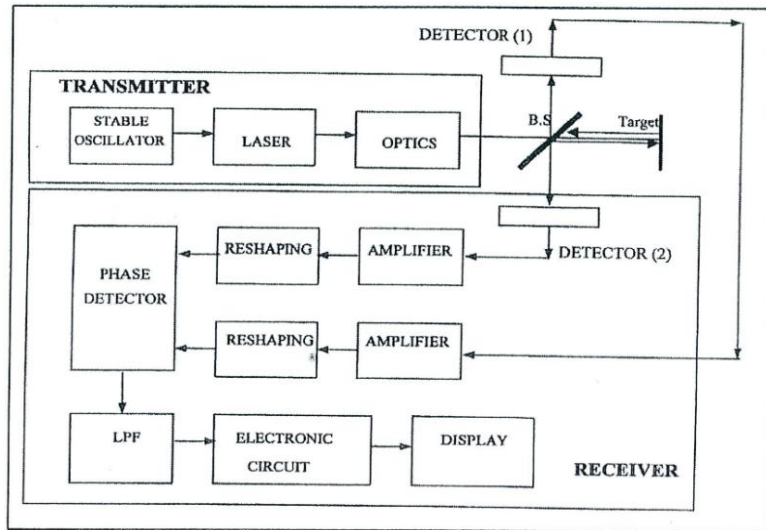

Fig.(7): Block diagram of the implemented CWSM laser ranging system.

The modulated laser beam is then pass through a beam splitter that divides the laser beam into two parts the first is the reference beam and the second is that transmitted to the target.

In the receiving part of the system the two beams, the reference and the reflected beams are detected, where the modulating sinusoidal waveform is recovered, then amplified and reshaped in the form of pulses. A phase detector detects the phase difference between the two signals, which are calibrated to give the range directly.

4. RESULTS:

a) Pulsed laser ranging system (Helwan):

Figure (8) shows the histogram drawn, using polynomial data fitting, for the range residuals for the satellite Lageos-1 which gives a mean value of 0.41413 ns (or 12.4239 cm), which was expected for the Laser used.

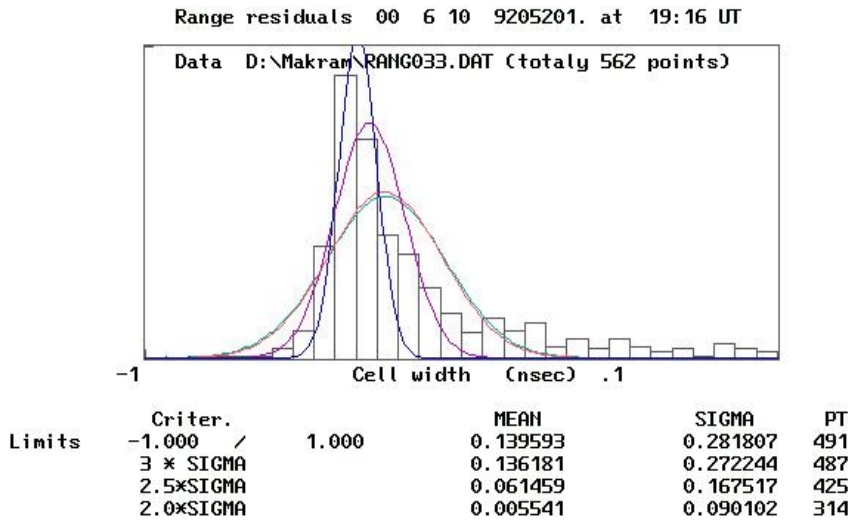

Fig.(8): A histogram of the range residual as computed for the satellite Topex.

b) CWSM laser ranging system:

A 1.00 MHz sinusoidal signal is used to modulate the laser diode. This frequency is chosen to give a reasonable signal to noise ratio and to satisfy our requirements for the maximum range to be covered (150 m). The target is placed at different ranges, and the corresponding values of phase shift $\Delta\phi$ are measured.

These results are illustrated in Figure (9). The results show a good linearity which may be represented by $R = \alpha(\Delta\phi) \pm \beta$, where the mean values of α and β are 23.8732 m/rad. and 7.037E-08 m respectively.

For each position of the target, the resolution in range ΔR was measured, by moving the target by a micro-translation stage till the output of the phase detector shows a change in the value of $\Delta\phi$. In our system, the mean value of the signal to noise ratio (S/N) was 246.7, which results in a mean value of phase resolution $\Delta\phi_{min}$ of ± 4.188 m rad. which corresponds to a range resolution of 96.7193 mm. The measured values of ΔR are shown in Figure (10).

The results show nearly constant resolution at small ranges, but as range R increase, an increase in ΔR was measured. This increase in ΔR at higher values of R is expected since the divergence of the laser beam will lead to a lower level of the reflected signal, and hence, less values of S/N ratio and higher values of $\Delta\phi_{min}$.

To test the dependence of ΔR on modulating frequency f_m , the target was fixed at 10m range, while ΔR was measured as a function of f_m , which is adjusted to 0.5 MHz, 1MHz, 1.5 MHz,, and 3.5 MHz. The results are shown in Figure (11), which show good agreement with the theoretical study.

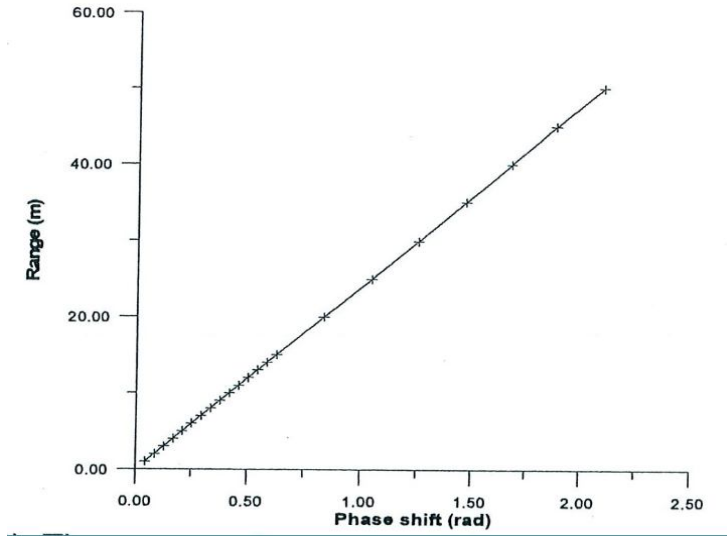

Fig.(9): The measured ranges as a function of phase shift.

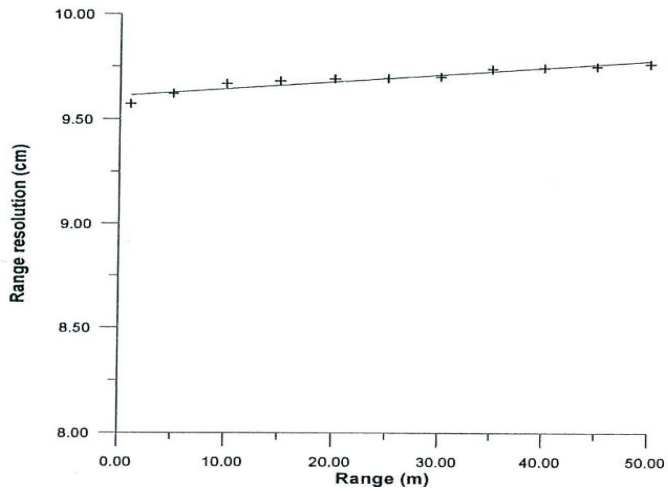

Fig.(10): Measured range resolution at different ranges.

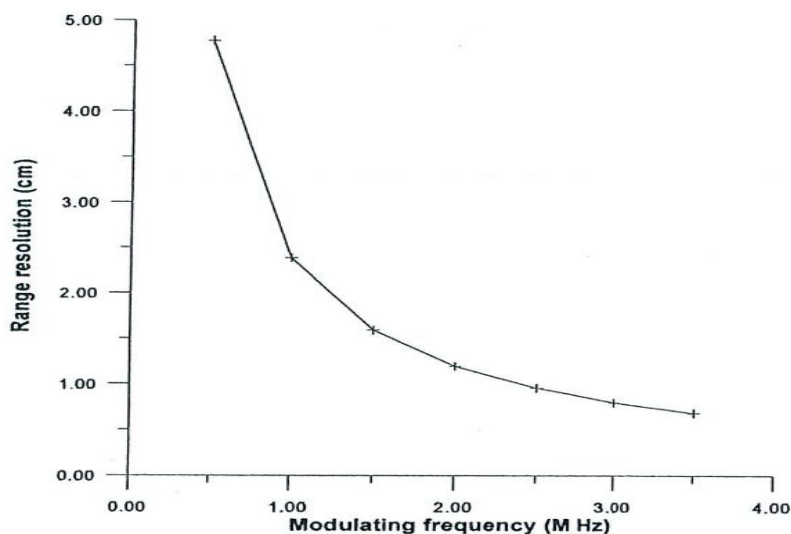

Fig.(11): Measured range resolution at different modulating frequencies.

CONCLUSIONS:

The main features of laser ranging systems in its two main modes, the pulsed mode and the continuous wave subcarrier mode (CWSM) have been studied. The main advantages of each mode have been discussed then proved out of experimental data. The following Table summarizes the main features of each technique.

Feature	Pulsed technique	CWSM technique
Max Range	- Theoretically unlimited - Practically limited by the intensity of signal returning back to receiver	- Limited by a phase delay of 2π rad.
Min Range	- Limited by the pulse width (blind range)	- Theoretically unlimited - Practically limited by phase which depends on S/N ratio
Use	Very large and medium ranges	Short ranges

Experimental results out of two laser ranging systems, the first is ready made while the second is designed and implemented in the lab, are given. Based on laser pulsed range system the position of the satellite "Lageos-1" is measured with an accuracy of 12.4239 cm. Based on continuous wave subcarrier modulation, a short range, laser range finder of maximum range 150 m, was designed and implemented. The system was tested at different modulating frequencies and different ranges. It was proved that as the modulating frequency increases, the range resolution of the

system becomes better. A signal to noise ratio of 23.92 dB was obtained, which resulted in a phase resolution of $\pm 4.188 \text{ m rad.}$ at modulating frequency of 1 MHz that gave a range resolution of 96.7193 mm.

REFERENCES:

1. Fahim, G.; Khalil, Kh. I. and Hanna, Y.S. 1996. "Data Analysis procedure of Helwan Satellite Laser Station". Bulletin of National Research Institute of Astronomy and Geophysics, Vol. XI, P. 1, pp. 12-23.
2. Fahim, G. 2003. "Improvements of the accuracy at Helwan satellite laser tracking station". NRIAG Journal of Astronomy and Geophysics, Vol. 2, No. 1, pp. 47-63.
3. Hovanessian, S.A. 1984. "Radar System Design and Analysis". Artech House.
4. Barton, D.K. 1988. "Modern Radar System Analysis". Norwood MA, Artech House.
5. Zmuda, H. and Toughlian, E.N. 1992. "Photonic Aspects of Modern Radar". Norwood MA, Artech House.
6. James, T.L. and David, E.P. 1992. "Industrial Lasers and Their Applications". Prentice Hall Press.
7. Grattan, K.T.V. and Meggitt, B.T. 1995. "Optical Fiber Sensor Technology". Cambridge University Press.
8. Chin, L. 1996. "Elements of optoelectronics and fiber optics". RR Donnelley & Sons Company.
9. Ahmed, M.M. and Gerges, A.S. 1998. "Study and implementation of a laser range finder with very small blind range". Technology and Armament magazine. Vol. 13, pp. 91.
10. Yatesenko, L.P.; Shore, B.W. and Bergmann, K. 2009. "An intuitive picture of the physics underlying optical ranging frequency shifted feedback lasers speeded by a phase-modulated field" Optics communications, pp. 2212-2216.
11. Baghos, B.B.; Tawadros, M.; Helali, Y.; Hamal, K.; Čech, M. and Jelinková, H. 1990. "Satellite laser ranging station at Helwan". Third Scientific General Meeting, Egypt, Cairo, pp. 21, Nov.
12. Jelinkov, H. "Laser transmitter Single Pulse/semi-train", 1989. Seventh International Workshop on laser ranging Instrumentation, Matera, Italy.

